

Large Built-In Cabinet Plans



by

Our Home from Scratch

Disclaimer

Our Home from Scratch LLC and its legal owners cannot be held responsible for any loss, damage, injury or death resulting from following the procedures or techniques described in these plans. Our Home from Scratch LLC and its legal owners assume no risk and cannot be held responsible for any misuse of these plans either directly or indirectly. They make no statements as to the weight or strength capacity of the item described in these plans.

These plans may contain errors and Our Home from Scratch LLC and its legal owners cannot be held responsible for any error. No guarantee is made as to the quality of any product that is described herein.

Always use appropriate Personal Protection Equipment when working with tools and exercise caution if taking any action associated with these plans.

Attempt at your own risk. Some woodworking skills are required.

This procedure contains affiliate links.

Distribution Policy

By downloading these plans you consent to this distribution policy. These plans are not to be distributed in anyway without the express consent of Our Home from Scratch LLC or its legal owners. The individual pictures or procedures contained herein are also not to be copied or shared.

Introduction

The plans for this large built-in cabinet were developed from the same built-in that is currently in our home, which was featured in our blog post series on [How to Make a Built-In Cabinet](#). Unlike the details found in the blog, these plans contain a complete material list, dimensions for lumber as well as step by step instructions. It can be built mostly from material found at your local hardware store and painted to match the trim in your home for a truly custom look.

The bottom portion of the cabinet features two sizable storage areas. The plans include shelves for each side. We left ours shelf-less to accommodate our kids' toys. The top section of the cabinet includes three wide shelf areas for books or other displayable items. To give the unit a real "built-in" look, the cabinet can be wrapped with baseboard and crown molding or if you prefer the molding can be left off for a simpler look.

If you get stuck on any particular part of these woodworking plans, feel free to email me at John@ourhomefromscratch.com with any questions you may have. You may also find our blog post on [How to Make a Built-In Cabinet](#) helpful since most of the work described in this procedure is identical to that post.

Additionally, this project uses 3-1/4" high baseboard molding and roughly 2-1/8" high crown molding. If your home has bigger molding and you would like the cabinet to match it, contact me for custom dimension resizing if available.

I hope you enjoy the challenge of building a large cabinet.

R,

John

Overall Dimensions:

Height: 94"

Width: 48"

Depth: 18:

Bottom Cabinet Dimensions:

Height: 35"

Width: 48"

Depth: 18"

Top Cabinet Dimensions:

Height: 59"

Width: 48"

Depth: 12"

Getting Started

These woodworking plans will take you step by step through the build of this cabinet system from start to finish. The first thing you should do is read through these procedures to familiarize yourself with the materials, tools and skill requirements necessary to complete them. The process described in these plans is presented in the same manner in which I built my own cabinets.

Tools

The tools I used for this project include the following:

1. [Table Saw with 60 tooth saw blade](#) and [Dado Blade Set](#)
2. [Miter Saw](#) (also with 60 tooth saw blade)
3. [Circular Saw](#)
4. [Cordless Drill](#)
5. [Router with 3/4" cutting bit](#)
6. [Pneumatic Brad Nailer](#)
7. [Kreg Pocket Hole Jig](#) with [clamp](#)
8. [Biscuit Joiner](#) (optional)
9. [K Body Clamps](#)
10. [Random Orbital Sander](#)

Materials List:

Listed below is a table with all the parts necessary to build these cabinets. I was able to purchase all of the lumber at my local large hardware store (Lowe's, Home Depot, etc.) The cabinet hardware including the hinges and door stops were purchased on Amazon.com. You will need to pick out your own door pulls.

Since this is a paint grade project, the hardwood I chose was Poplar. You can also use Maple or Pine for paint grade work. Although, Pine tends to be much softer than Maple or Poplar and it may show more wear over time compared to Poplar and Maple. If you would like to build a stained wood built-in, simply replace the Poplar and the Birch plywood on the material list with the wood and plywood of your choice (Oak, Cherry, Pine, etc.)

TABLE 1: MATERIAL LIST

	<u>Required Items</u>	<u>Quantity</u>
1	1x2x8 Poplar Boards (Actual 3/4"x1.5"x8')	5
2	1x2x6 Poplar Boards (Actual 3/4"x1.5"x6')	1
3	1x3x8 Poplar Boards (Actual 3/4"x 2-1/2"x8')	4
4	3/4" Thick 4'x8' Birch Plywood Sheets	3
5	1/2" Thick 4'x4' Birch Plywood Sheet	1
6	Inset Cabinet Door Hinges	4
7	Inset Cabinet Door Stops	2
8	Model #53 Crown Molding (available at Lowe's)	10'
9	3-1/4" High Baseboard Molding	10'
10	1-1/4" Long Pocket Screws	20
11	Wood Glue	
12	Small Brad Nails	
13	Shelf Pins	20
	<u>Optional Items</u>	
14	Rockler JIG IT Shelving Jig and 1/4" Bit Set	1

The “Optional Items” section includes a shelf pin jig, which is also available from Amazon.com. This particular jig comes with a special drill bit that allows you to use a standard cordless drill to add shelf pin holes. If you do not own one, I highly recommend you purchase one as you can use them on this cabinet and nearly every cabinet project in the future. You will need to add pin holes for the shelves or the shelves won’t have anything to rest on.

Material Preparation:

Plywood

With all of the material purchased from the “Materials” section, it’s time to cut all of the wood to the required dimensions. We’ll start with the plywood. The individual plywood parts are called out in the table below. In this procedure, I’m going to refer to them by their assigned name, rather than by a letter or a number. Please note that the Door Panels are cut from ½” thick plywood, where the rest is ¾”.

TABLE 2: PLYWOOD PARTS

<u>Plywood Items</u>	<u>Thickness</u>	<u>Width (in)</u>	<u>Length (in)</u>	<u>Quantity</u>
Bottom Cabinet Side	3/4"	16 1/4	34 1/4	2
Bottom Cabinet Back	3/4"	34 1/4	44 3/4	1
Bottom Cabinet Bottom	3/4"	15 1/8	44 3/4	1
Bottom Cabinet Divider	3/4"	15 1/8	29 1/8	1
Bottom Cabinet Shelf	3/4"	14 3/8	21 1/2	2
Countertop	3/4"	17 1/4	46 1/2	1
Top Cabinet Sides	3/4"	11 1/4	57 3/8	2
Top Cabinet Back	3/4"	44 3/4	57 3/8	1
Top Cabinet Top	3/4"	10 1/8	44 3/4	1
Top Cabinet Shelf	3/4"	9 5/8	43 3/4	3
Door Panel	1/2"	18 1/8*	24 3/8*	2

*For full overlay doors, add 1-1/2” to these dimensions.

I always recommend you use “cut sheets” to assist with cutting the plywood parts from the sheet goods. A cut sheet is just a map of where each plywood piece can be cut out. It’s designed to assist with the process and is also critical to minimize the amount of wasted wood. Figure 1 is the cut sheet for the $\frac{3}{4}$ ” thick plywood. Figure 2 is the cut sheet for the $\frac{1}{2}$ ” thick plywood. Three sheets of $\frac{3}{4}$ ” thick plywood are shown in Figure 1 and each piece is labeled. A full-sized version of Figure 1 is available at the end of these plans in case it’s difficult to read the print.

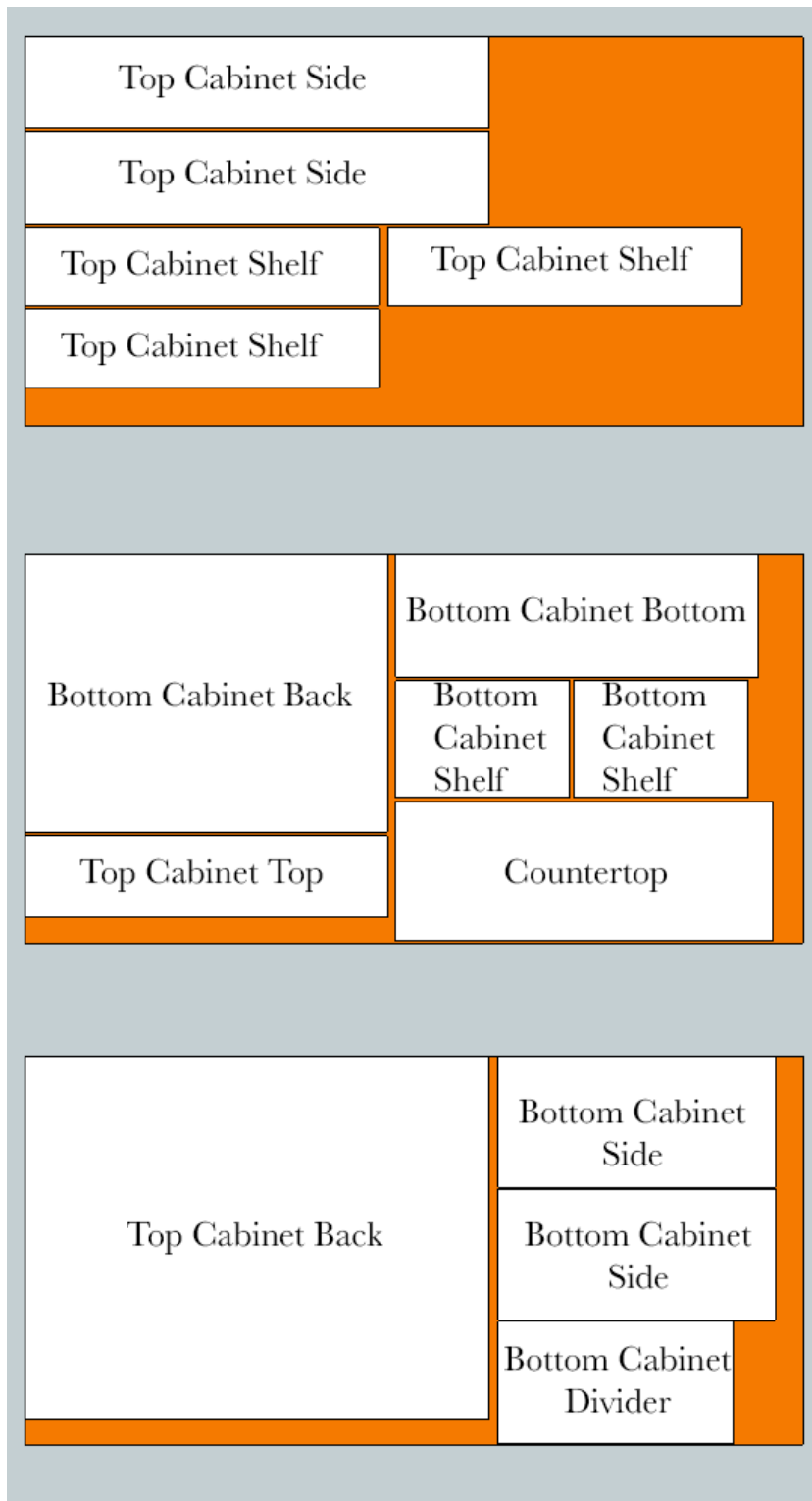

Figure 1: 3/4" Thick Plywood Cut Sheets

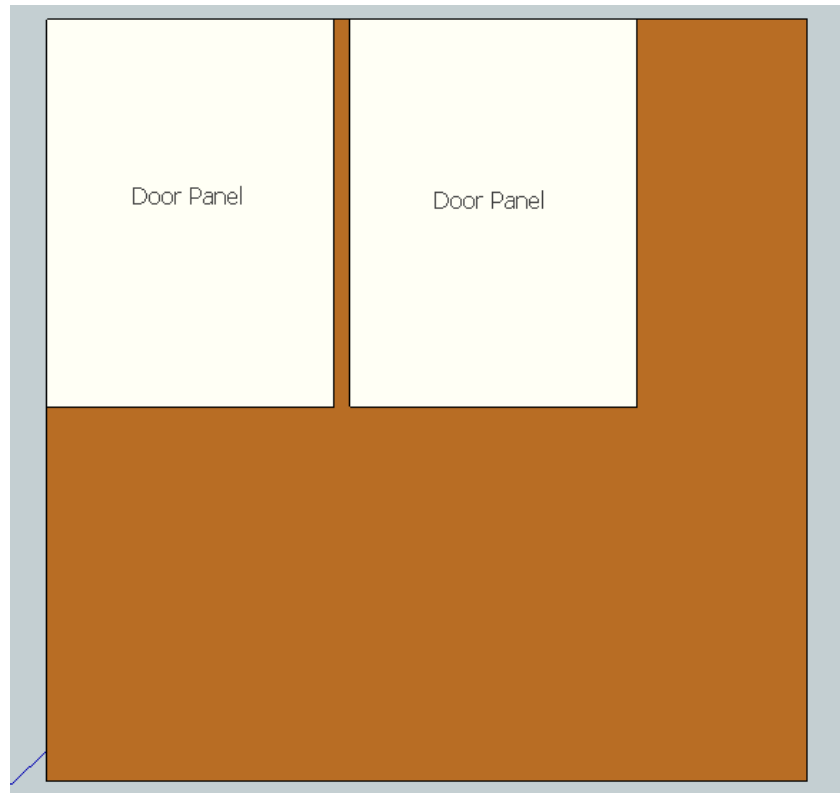

Figure 2: ½" Thick Plywood Cut Sheet

To cut the plywood pieces out, I used a table saw with a sharp blade and high teeth count (60 or more). I also used a handheld circular saw for the cuts that are not as safe on the table saw. To achieve a straight, even cut with a circular saw, I clamped a straight edge (a level or a board) to the work and ran the circular saw against the straight edge.

Hardwood

Once the plywood has been all cut out of the sheets, it's time to cut the hardwood to their final dimension. The individual hardwood components are called out in Table 3. For ease of assembly later on, each part is referred to by a letter. There are nine 2" wide pieces (4 door stiles, 4 door rails and the top cabinet rail). Those boards will need to be narrowed down to 2" from the 2.5" wide boards at the table saw. Additionally, there are eight 1" wide boards that will need to be narrowed down from 1-1/2".

To cut the boards to their length, I used the miter saw with a high tooth count blade (60+). Be sure to cut the boards to their respective lengths BEFORE narrowing any down.

TABLE 3: HARDWOOD DIMENSIONS

<u>Item</u>	<u>Description</u>	<u>Width</u>	<u>Length</u>	<u>Quantity</u>
A	Bottom Cabinet Stiles	1 1/2	34 1/4	2
B	Bottom Cabinet Top Rail	2	43	1
C	Bottom Cabinet Bottom Rail	2 1/2	43	1
D	Bottom Cabinet Divider	1 1/2	27	1
E	Door Stiles	2	26 7/8**	4
F	Door Rails	2	18 1/8**	4
G	Top Cabinet Stiles	1 1/2	57 3/8	2
H	Top Cabinet Rails	2 1/2	43	1
I	Bottom Shelf Fronts	1	21 1/2	2
J	Top Shelf Fronts	1	43 3/4	3
K	Countertop Edging Side	1	18*	2
L	Countertop Edging Front	1	48*	1

*Leave these parts a little long to allow for more accurate fitting on countertop later in this procedure.

**For full overlay doors, add 1-1/2" to these lengths.

Instead of cut sheets for the hardwood, here is a cut list for each board width that details which parts can be cut from specific boards in order to minimize waste. It's similar to the plywood cut sheet, except it's not in graphical form.

1-1/2" Wide Boards:

- Board 1: A, A, D
- Board 2: G, K, K
- Board 3: G, I
- Board 4: J, L
- Board 5: J, J
- Board 6 (6' Long Board): I

2-1/2" Wide Boards:

- Board 1: B, C
- Board 2: E, E, E
- Board 3: F, F, F, F
- Board 4: E, H

Machining Grooves

Once all the plywood and hardwood has been sized and cut to their final dimensions (See Tables 2 and 3), it's time to add grooves into certain plywood parts. These grooves are absolutely necessary to hold the cabinets together and will help align entire sections during assembly. The grooves can either be added at the table saw using dado blades or with a router and a $\frac{3}{4}$ " cutting bit. All grooves will be $\frac{3}{4}$ " wide and $\frac{3}{8}$ " deep.

The procedures may seem to jump around from one piece to the next and there's a reason for that. If your table saw is setup for a dado cut 1-1/2" away from the fence, it's better to make all the cuts on all the boards that receive that same cut then to make the first, then another and then go back to the first.

To make things easier, here is a check sheet of all the grooves that need to be added. Cross them off as you complete them.

1. Bottom Cabinet Side: Short Side Groove
2. Bottom Cabinet Back: Long Side Groove
3. Bottom Cabinet Back: Perpendicular Center Groove Along Width
4. Bottom Cabinet Side: Long Side Groove
5. Top Cabinet Side: Short Side Groove
6. Top Cabinet Side: Long Side Groove
7. Top Cabinet Back: Short Side Groove
8. Bottom Cabinet Bottom: Center Groove Along Width

We'll start the grooving process with the Bottom Cabinet Sides. Figure 3 shows the two side pieces with the grooves cut.

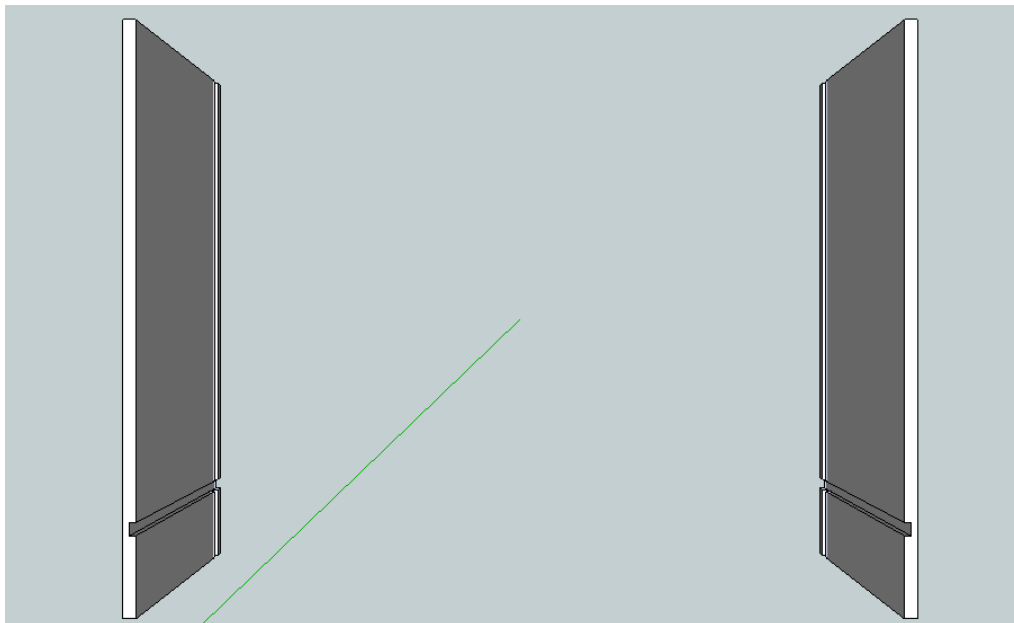

Figure 3: Bottom Cabinet Sides with Two Grooves

The first groove is along the bottom of the side, which is the short side. Figure 4 shows a close up of the first groove.

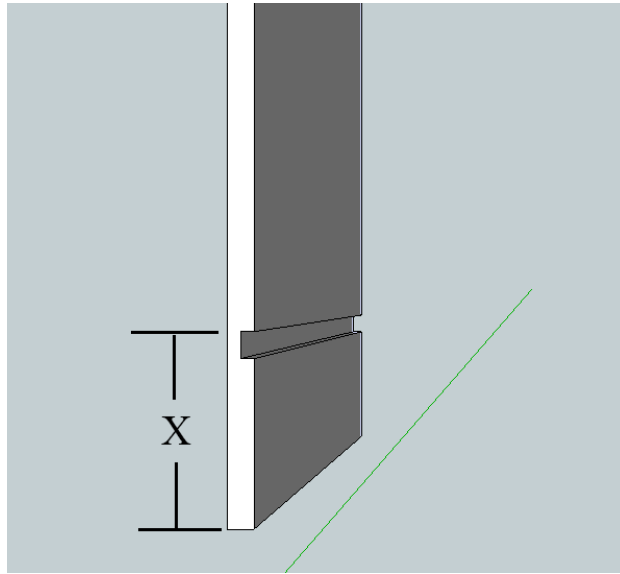

Figure 4: Bottom Cabinet Side; Bottom Groove

The “x” mark indicates the distance from the bottom edge of the board to the top edge of the groove. In this case, “x” is equal to 5-1/2”. Again, this groove is along the short side of this piece. That “x” groove must also be made to the Bottom Cabinet Back. It will span the length of this back section as illustrated in Figure 5. The Bottom Cabinet Back will also receive a second groove perpendicular to the first located in the center of the board.

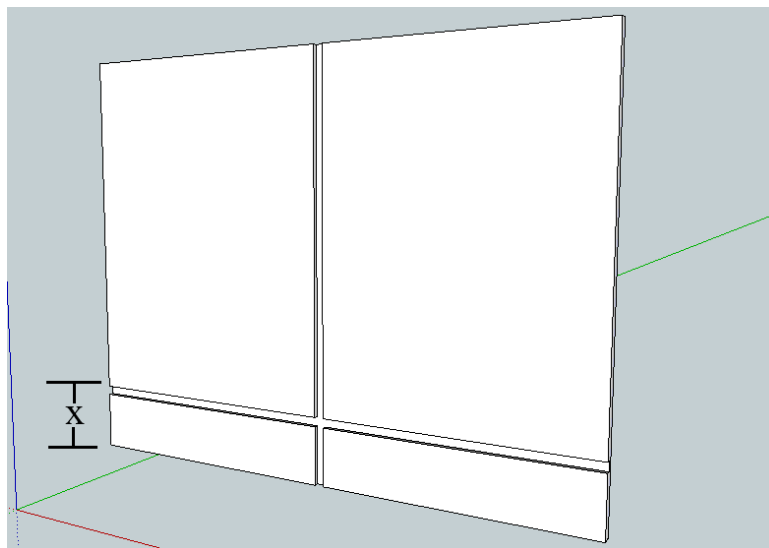

Figure 5: Bottom Cabinet Back; Bottom and Middle Grooves

Each Bottom Cabinet Side also receives a groove along the length. Figure 6 shows a top view of the Bottom Cabinet Side. In this figure, “y” is the distance

from the edge of board to the outside edge of the groove. For this cabinet build, “y” is equal to 1-1/2”. Make sure that the second side piece receives a groove so that it is a mirror image of the first side piece and not identical to it.

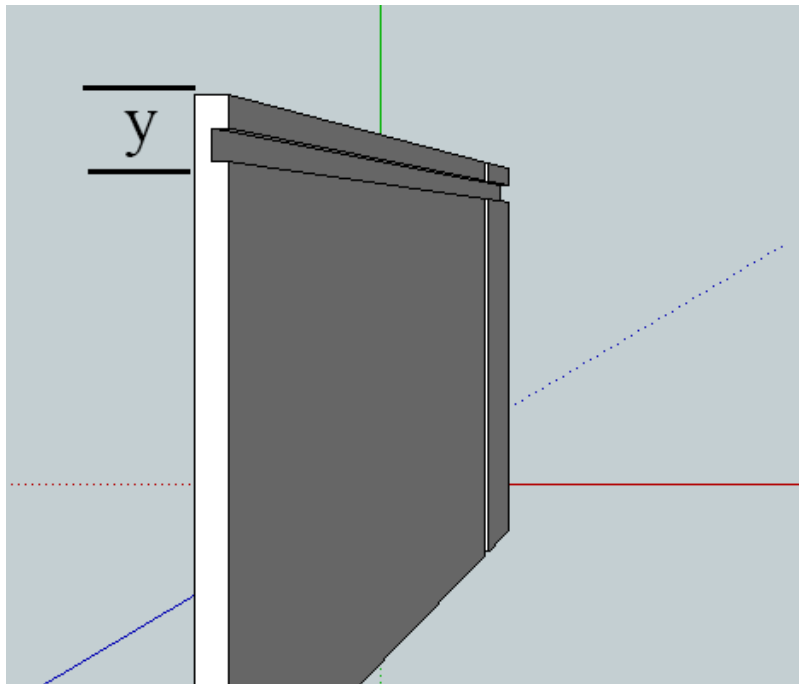

Figure 6: Bottom Cabinet Side; Long Groove

With your tooling setup for the “y” groove, repeat the “y” cuts on the Top Cabinet Sides sections. The cuts will be located similarly to the grooves on the Bottom Sides as shown in Figure 7. Again, make sure that the second side piece

receives a groove so that it is a mirror image of the first side piece and not identical to it.

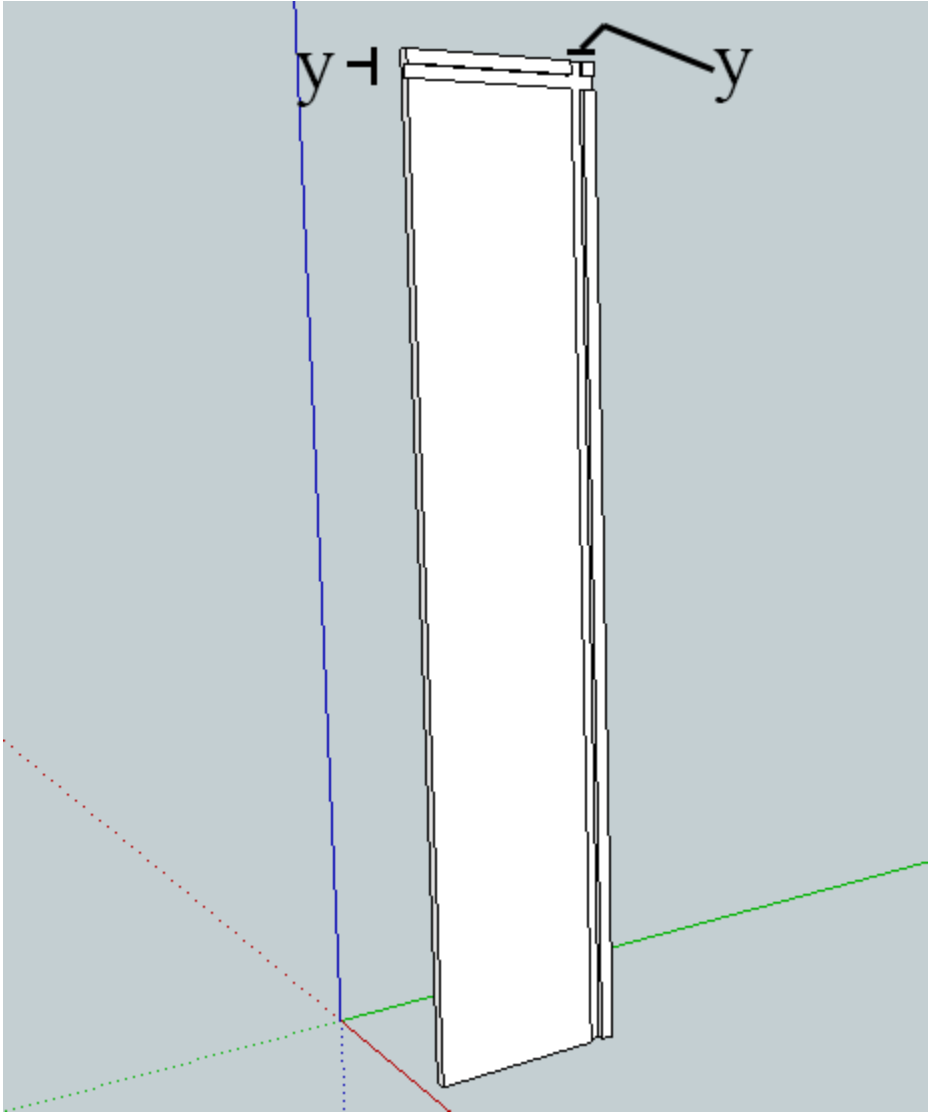

Figure 7: Top Sides with Two Grooves

The Top Cabinet Back will also receive this same “y” groove along the length of one edge. The Top Cabinet Back can be seen in Figure 8 with the groove cut.

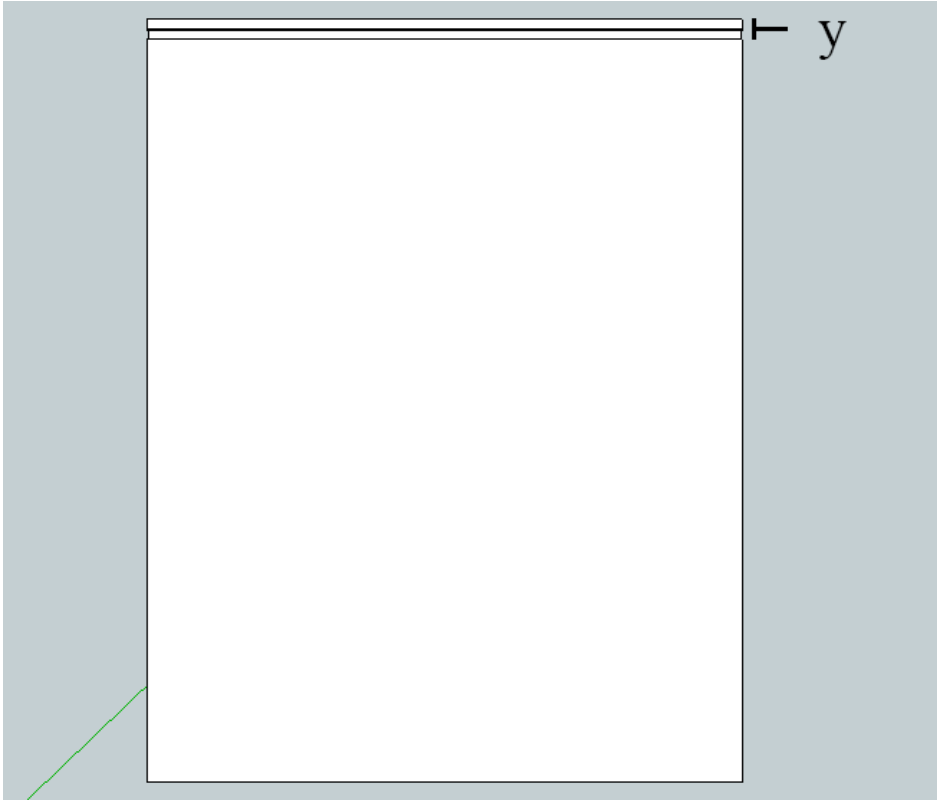

Figure 8: Top Cabinet Back with Groove

The last groove will be on the Bottom Cabinet Bottom. This board will receive a groove in the center that will run along the width as seen in Figure 9.

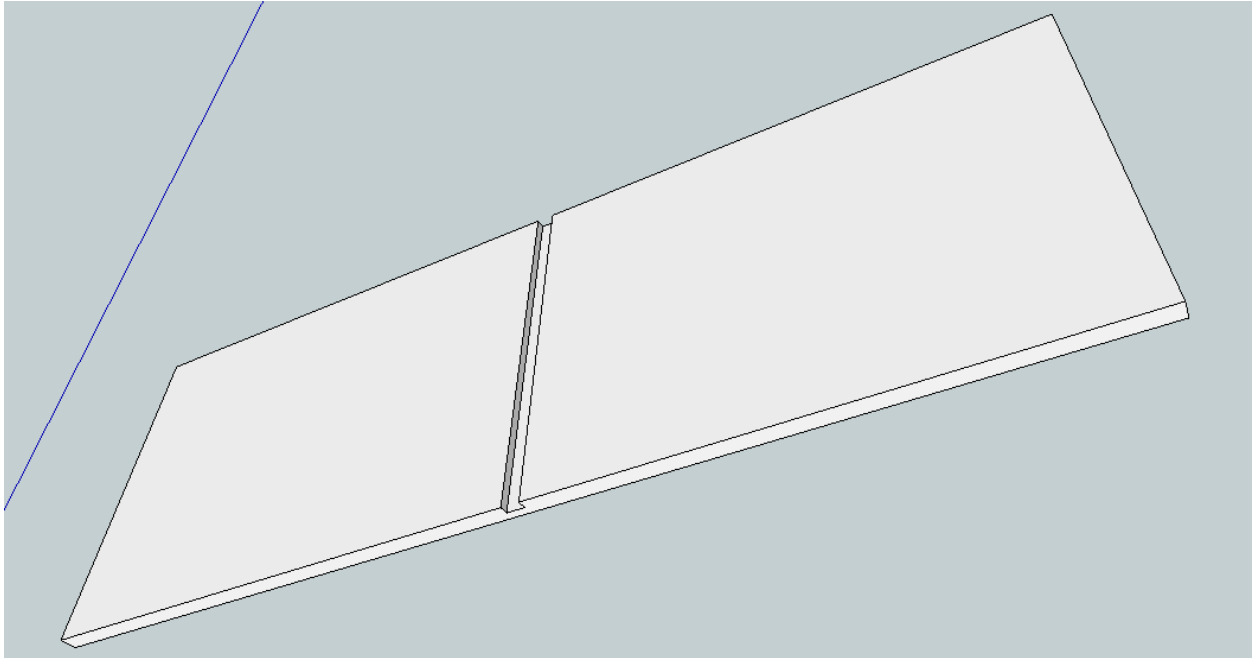

Figure 9: Bottom Cabinet Bottom with Center Groove along Width

Assembly:

Face Frame Construction

The face frames for both the bottom and top cabinets will be constructed using pocket screws and wood glue. Before drilling the pocket screw holes, inspect the bottom cabinet face frame boards (A, A, B, C, D) for dings and defects. The sides with any imperfections should be marked and positioned so that the pocket holes are drilled there. The arrangement of the boards and the pocket hole locations for the bottom cabinet are illustrated in Figure 10. Mark the location of the pocket holes then drill them out using a Kreg jig.

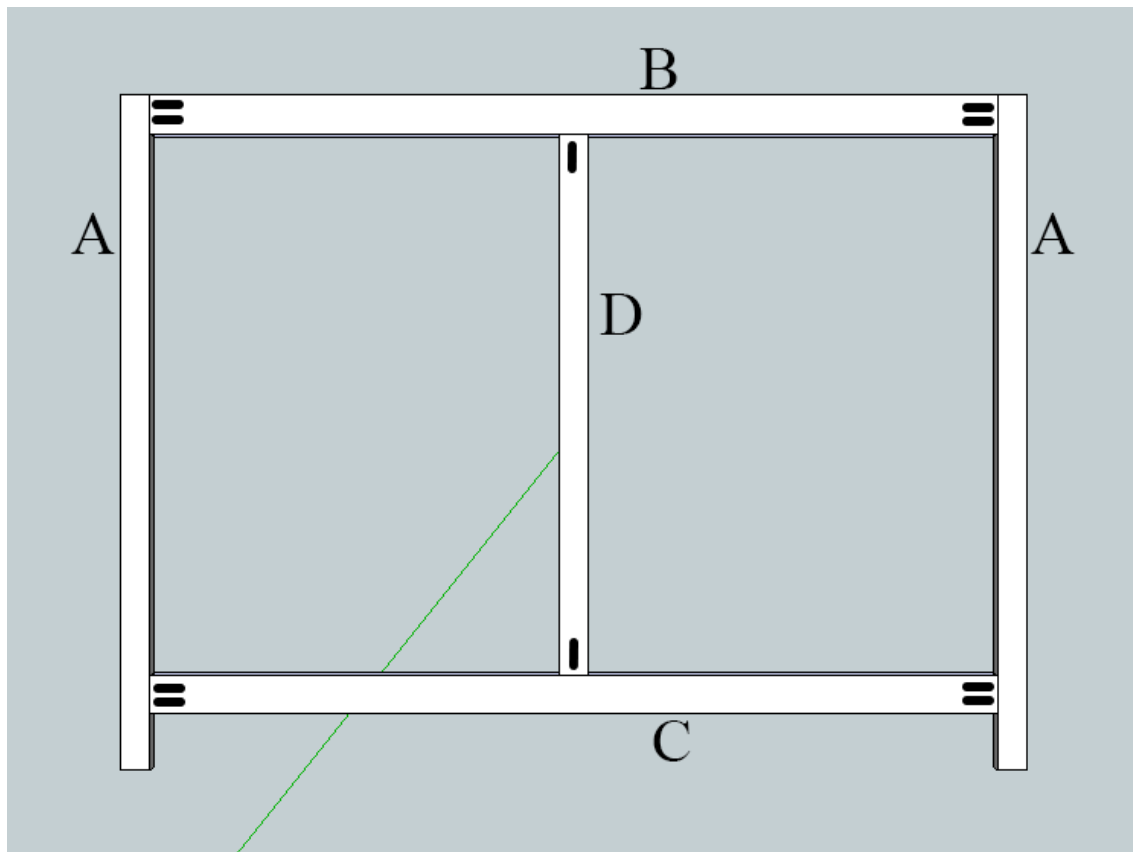

Figure 10: Bottom Cabinet Face Frame Arrangement and Pocket Hole Locations

When all the holes have been drilled, join the pieces together using a dab of wood glue in the joint and then the pocket screws once the openings have been checked verified as square. To check for square, use a measuring tape and measure the diagonals of each door opening. All four measurements should be within 1/16" of each other.

The top of the A boards should be flush to the top of the B board. The D board should be centered on both the C and B boards. The ends of the C board should also be equal distances up from the bottom edges of the A boards.

Repeat this process for the top cabinet face frame as illustrated in Figure 11 using boards H and G.

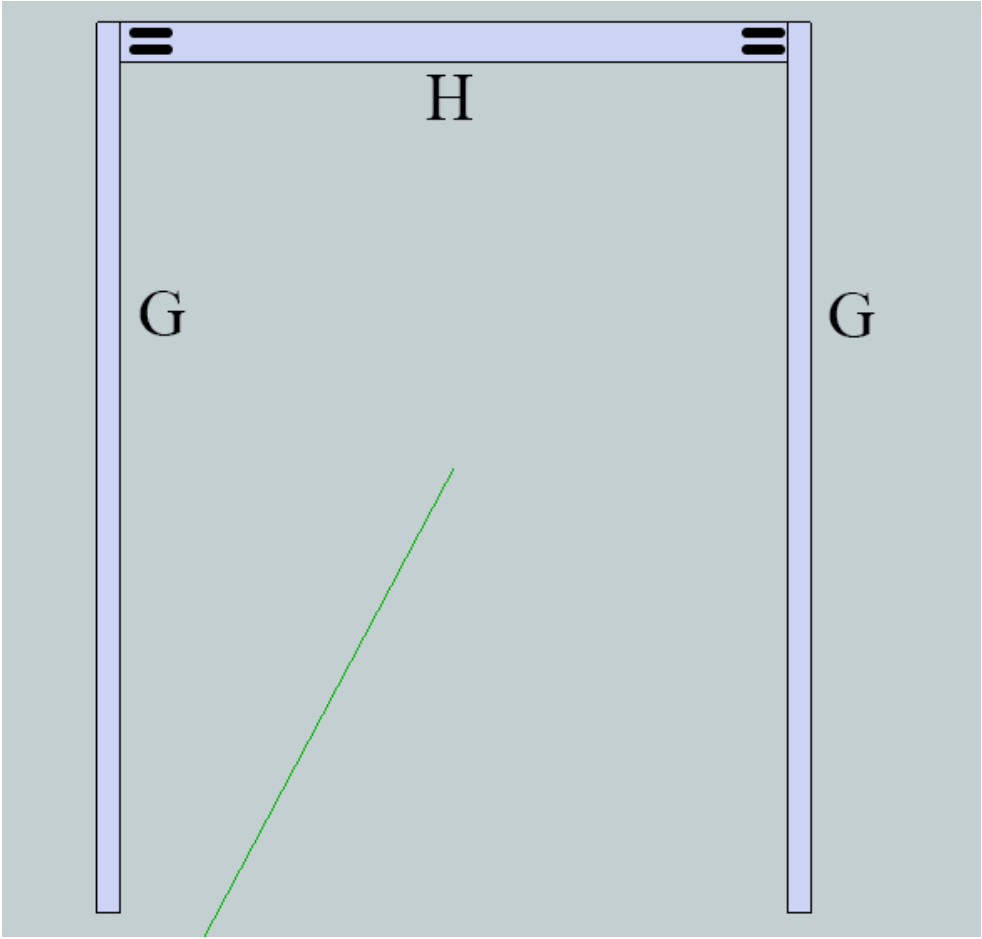

Figure 11: Top Cabinet Face Frame Arrangement and Pocket Hole Locations

Door Construction

The doors for this built-in cabinet are shaker style and are inset into the cabinet. Inset doors are less common and more difficult to make than regular overlay doors. However, inset doors are more indicative of a custom built cabinet and therefore can be more desirable. If you prefer the look of an overlay door, just add 1-1/2" to the lengths of the door stiles and rails as well as to the length AND width of the door panels.

Sizing and building the doors is the hardest part of this procedure. The dimensions provided in the hardwood dimension table are based upon the bottom cabinet face frame being built exactly as specified and totally square. Obviously, that doesn't always happen. Small errors in the build can crop up which can, for example, cause one door opening to be 1/8" wider on the bottom than the other. In that case, one door will be too small and one will be too large.

Ideally, the doors should have a small gap all the way around them equal to roughly 1/16" to just shy of 1/8". There are a couple ways to size and fit the doors into the face frame. In any case, I recommend you delay gluing the door together until you know the door fits in the face frame opening appropriately.

Option 1: You can go directly off the measurements provided in the hardwood and plywood dimension tables and build the door without comparing it to the face frame. If the door is slightly larger than the opening, you can shave some material off at the table saw or with a hand plane. If the door is way too small, then you will have to get additional wood and remake either the stiles or the rails.

Option 2: You size and build the doors directly from the face frame. You measure the openings on the face frame and ensure they are square and equal. If the face frame is slightly off square or one door side is slightly larger than the other, then you can adjust the door stile and rail dimensions each to get the right fit.

When I built my cabinet, I essentially used Option 2. To make this door build easier for you, I've included a link to a YouTube video where I demonstrate exactly how I built the doors for my cabinet. The video includes additional tips that you can choose to follow or ignore.

Here's a link to that video:



Click on the picture to be directed to YouTube or [click here](#).

Now that you've watched the video, let's recap the basic machining steps for the door parts.

1. Add a 3/4" deep groove in the center of the edge on **both** the door rail and stiles as seen in Figure 12.

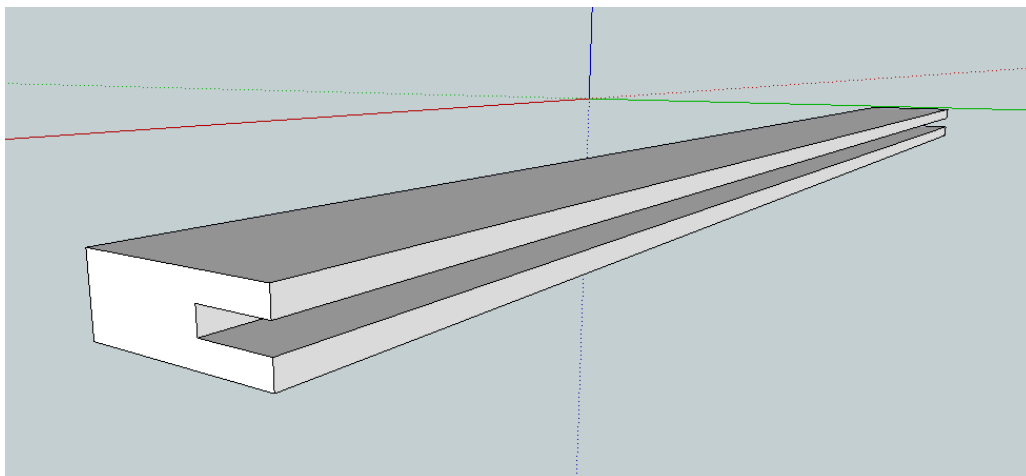

Figure 12: Door Stile with Groove

2. On each end of the rail boards, remove material to expose a $\frac{1}{4}$ " thick tongue centered on the edge that is $\frac{3}{4}$ " long similar to the illustration in Figure 13. The tongue should fit snugly into the groove on the stiles.

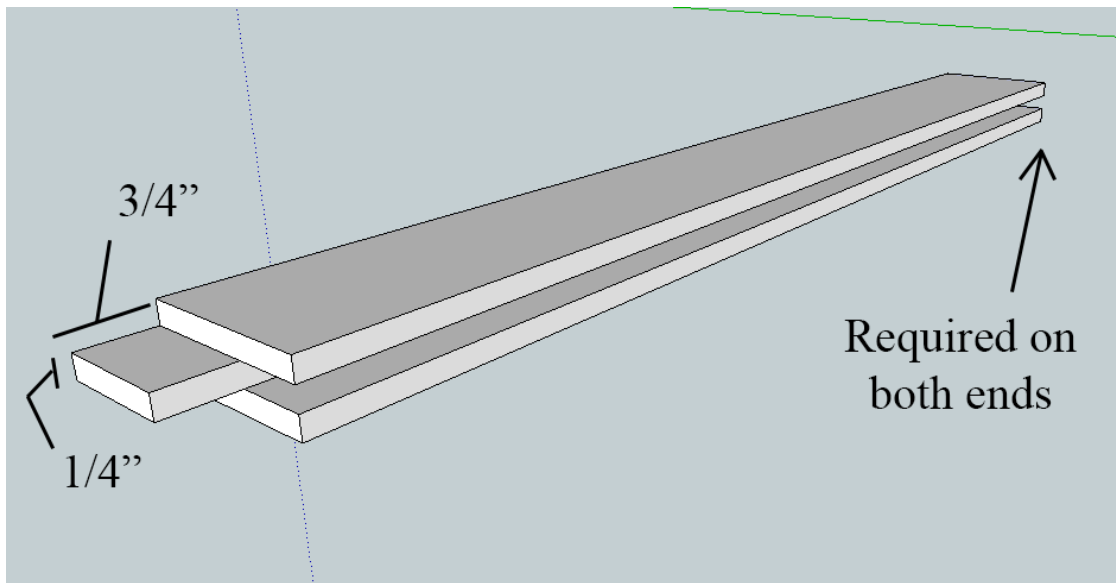

Figure 13: Door Rail with Tongue and Groove

3. Remove a $\frac{1}{2}$ " wide, $\frac{1}{4}$ " thick ring around the door panels. This will allow the panel to fit into the groove on the rails and stiles. This cut is referred to as a rebate or a rabbet cut. See Figure 14.

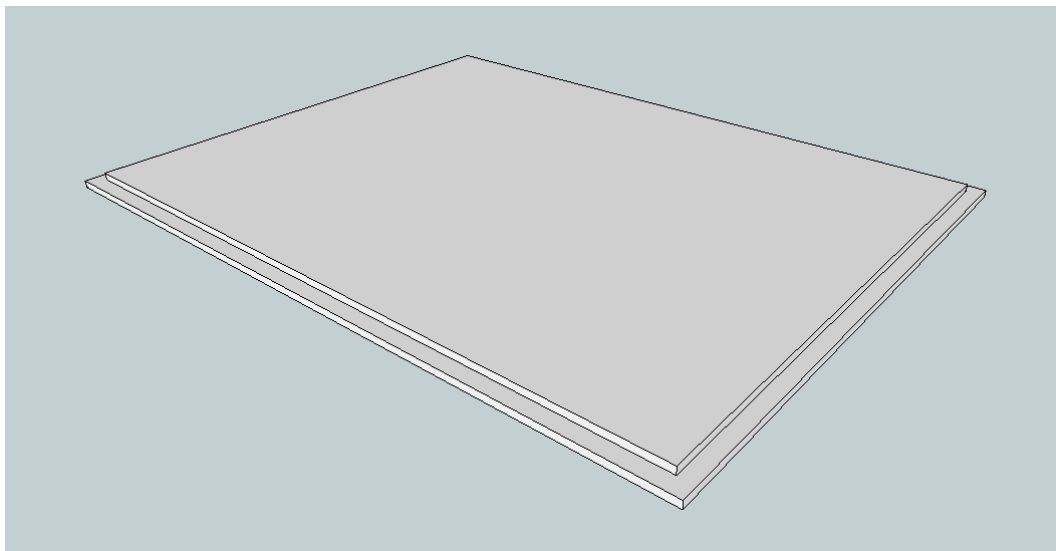

Figure 14: Door Panel with Rabbet Cut

4. Assemble the door panel without glue by inserting the door panel into the rail groove and then the door and rails into the stiles. The side of the door panel with the rabbet should be facing the back of the door. All joints should be tight. Test fit the dry door assembly into the door opening. It helps if the hinge is inserted into the door gap to allow for a true test fit. The door should have a consistent gap all the way around it. Make adjustments as necessary. See Figure 15.

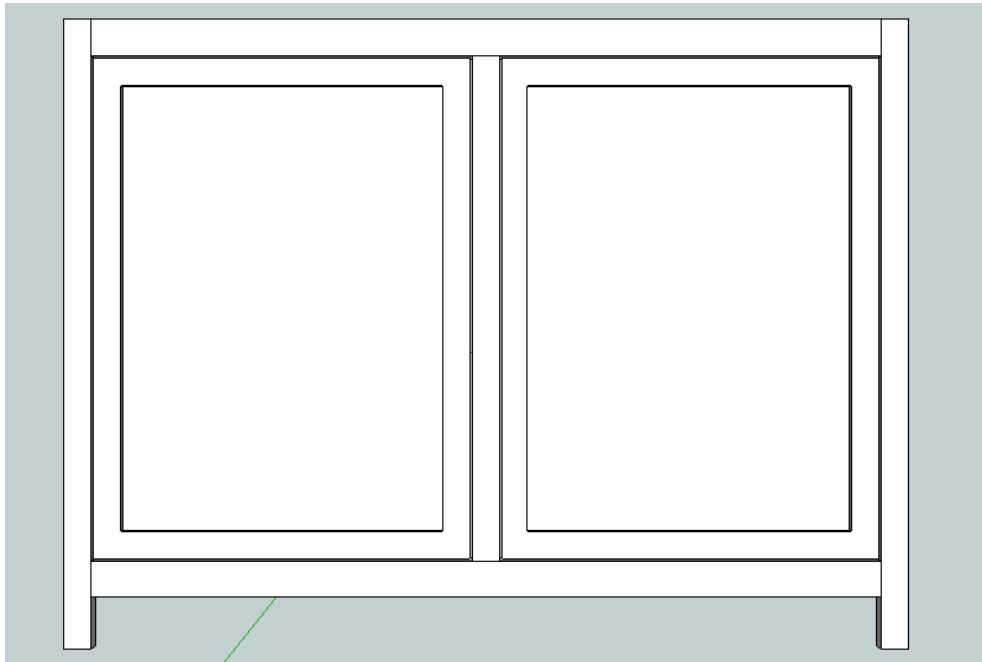

Figure 15: Doors Test Fit Inside of Face Frame

5. Disassemble the door. Apply a liberal amount of wood glue to the rail tongues only. Reassemble the door and clamp together with the clamps placed against the stiles to squeeze the rail-stile joint together. Wipe off any excess glue with a moist paper rag. Allow the glue to set overnight before releasing from the clamps.

Cabinet Box Assembly

With the face frames and doors built, the boxes can now be assembled.

1. Apply a liberal amount of wood glue into the long groove along one of the Bottom Cabinet Sides. Insert the Bottom Cabinet Back into that groove so that the bottom grooves align. These two pieces can be held together for easier handling by toe-nailing a couple of short brand nails into the joint area or from the outside of the side piece into the groove. Repeat this glue and assembly process with the other Bottom Cabinet Side piece as shown in Figure 16. Any excess glue should be wiped off with a moist rag.

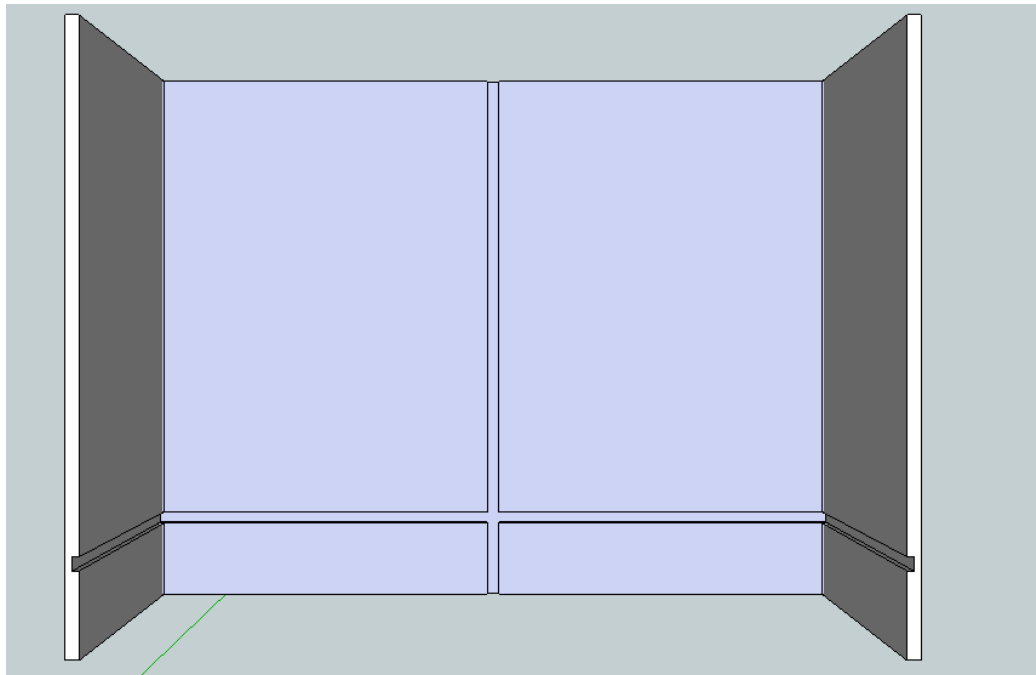

Figure 16: Bottom Cabinet Sides and Back Assembled

2. Next up is the Bottom Cabinet Bottom. Apply a liberal amount of wood glue into the bottom groove that spans the Bottom Cabinet Sides and Back pieces. Insert the Bottom Cabinet Bottom into the groove and flush it up with the front of the sides. The groove in the bottom piece should be facing up and aligned with the groove in the back piece. Again, the bottom piece can be pinned in place with some brad nails. See Figure 17.

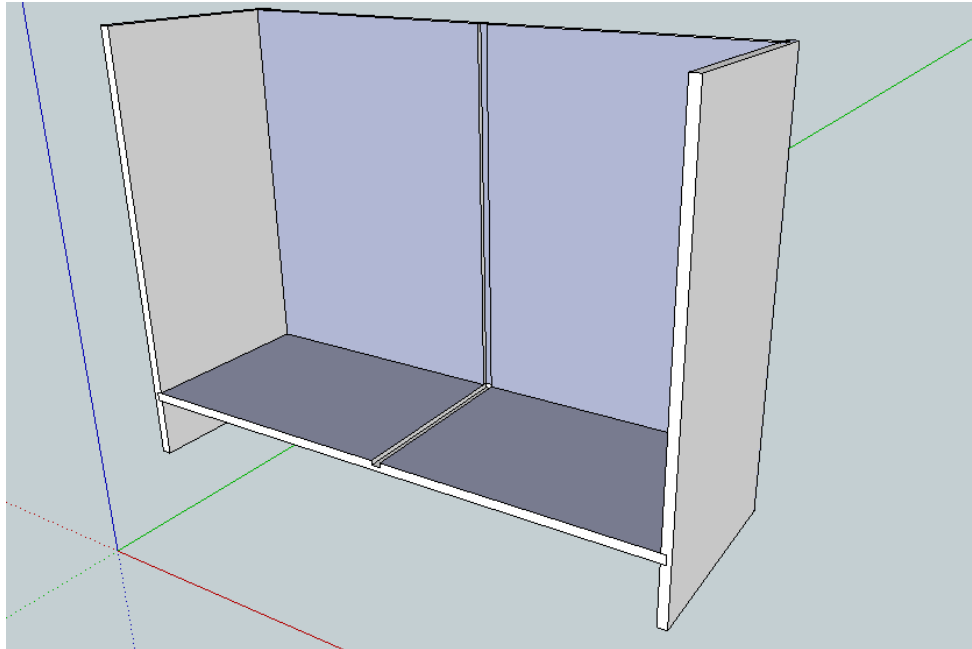

Figure 17: Bottom Cabinet Bottom Added to Assembly

3. The Bottom Cabinet Divider is the next piece to be inserted. Apply a liberal bead of wood glue into the grooves on the bottom and back sections. Insert the divider into the groove and flush the divider with the front edge of the bottom. The divider can be held in place with either brad nails from behind or below or wood screws since they won't be seen. See Figure 18.

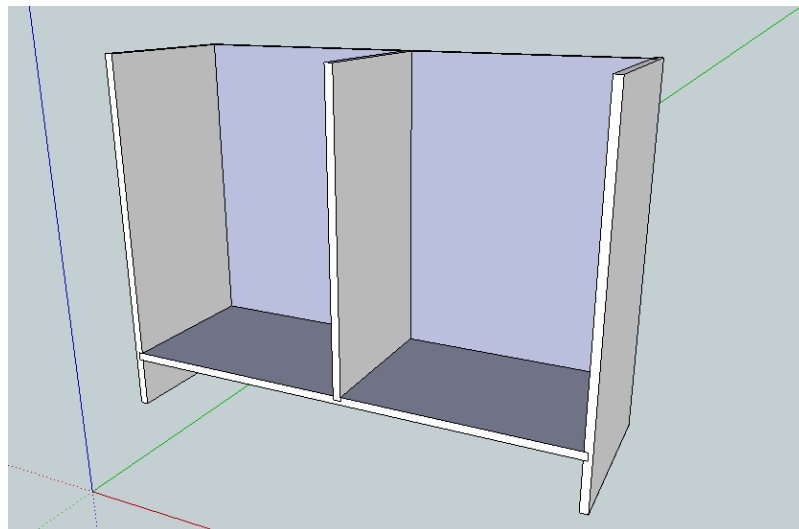

Figure 18: Bottom Cabinet Assembled

4. The face frame can now be attached to the bottom cabinet assembly using either brad nails through the front of the face frame, inconspicuously located pocket hole screws or biscuits. If you choose to use pocket screws, they can be located on the side pieces at two locations: a) the very bottom of the side below the bottom piece and b) near the top of the side. Both locations should be pretty out of the way.

The face frame is designed to be 1/2" longer than the box so it will overhang each side by 1/4". The top of the face frame should be flush with the top of the cabinet box. The Bottom Cabinet Bottom will sit 1/4" higher than the top of the bottom face frame rail, part C.

The entire front edge of the plywood should get a coating of wood glue before applying the face frame. The face frame should be clamped to the cabinet overnight to allow the glue to set. See Figure 19. The doors DO NOT need to be added until after painting. Recommend you leave them off until that time.

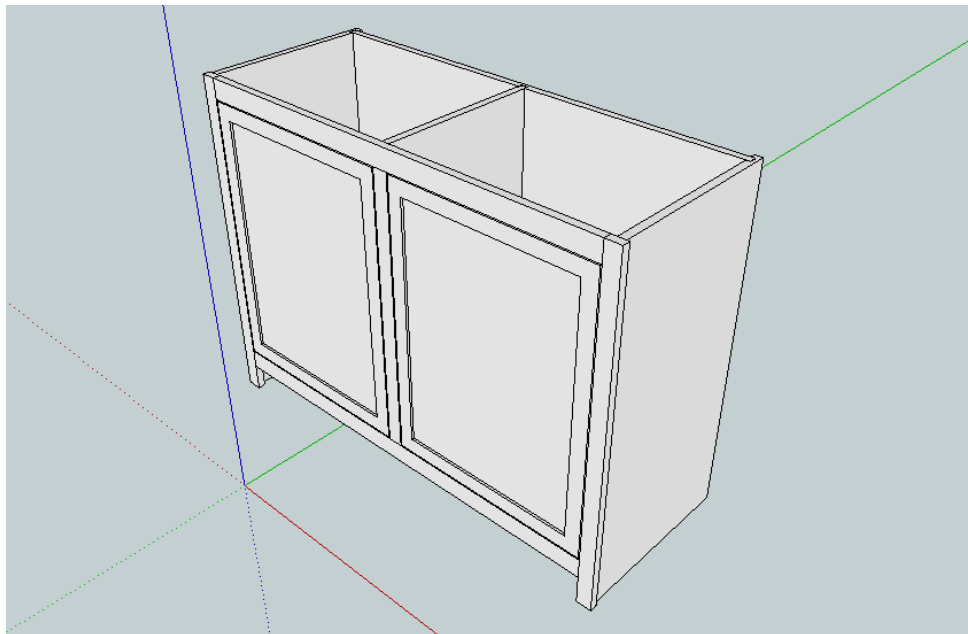

Figure 19: Face Frame Attached to the Cabinet Box

5. The countertop can now be assembled. The plywood countertop section simply gets trimmed out with the Countertop Edging boards. The ends are

cut at 45 degrees and get attached to the plywood with glue and brad nails. See Figure 20.

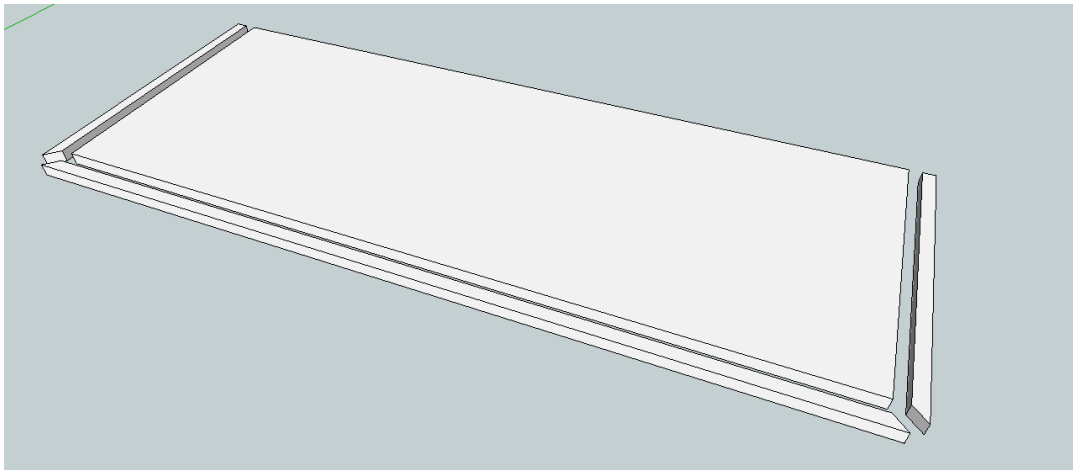

Figure 20: Countertop

6. The countertop gets attached to the bottom cabinet by using pocket screws. The pocket screw holes can be located on the back of the cabinet as well as on the interior side of the face frame. Apply a liberal bead of glue to the top of the cabinet box. Rest the countertop onto the box. The back of the countertop should be flush with the back of the box. It should overhang the front and sides by 1". See Figures 21 and 22.

This step pretty much completes the construction of the bottom cabinet. The doors can stay off until after the cabinet is painted and mounted to the wall.

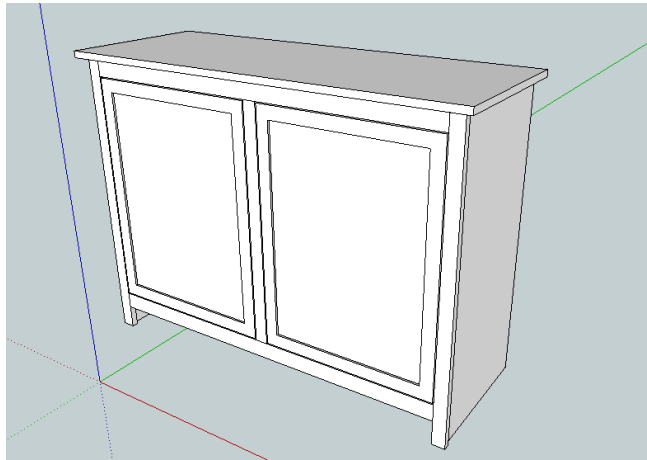

Figure 21: Assembled Bottom Cabinet

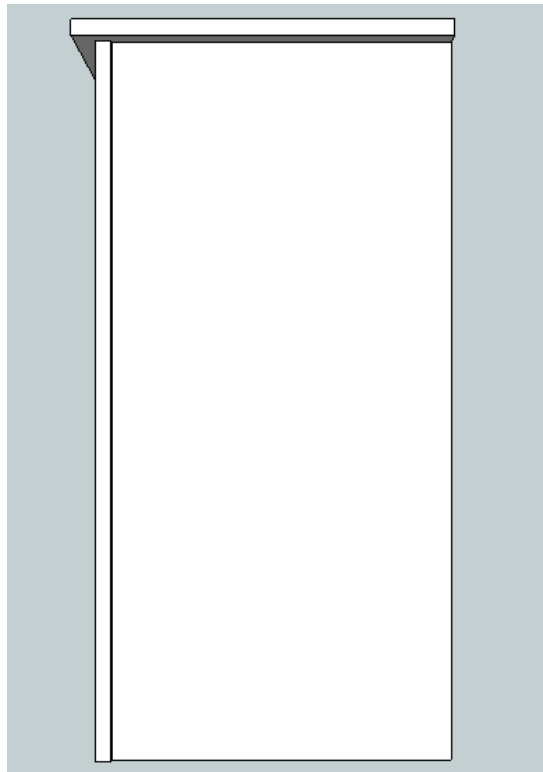

Figure 22: Side view of Bottom Cabinet

7. The top cabinet is assembled in an identical manner to the bottom cabinet. The sides get wood glue in their grooves and the back gets inserted. See Figure 23.

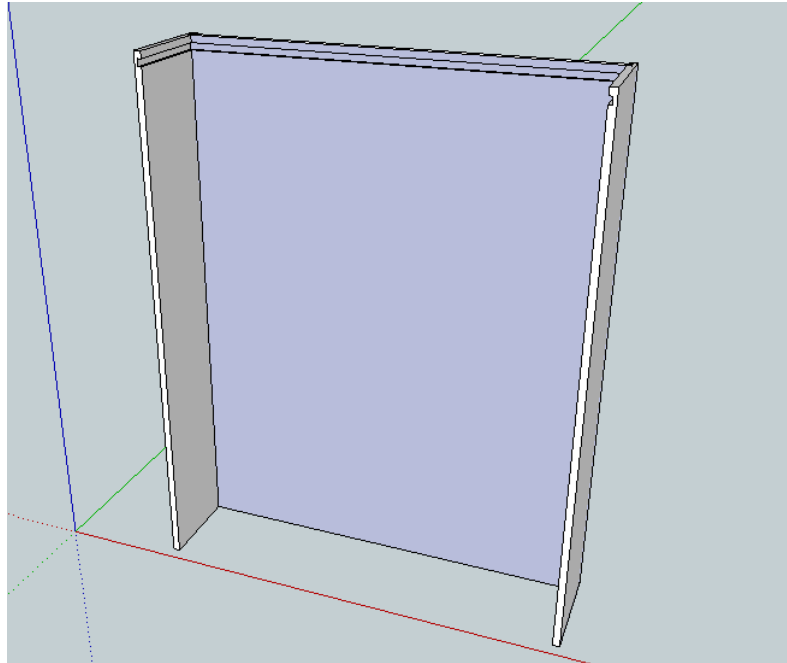

Figure 23: Top Cabinet Sides and Back

8. The Top Cabinet Top gets added with glue and nails. Make sure to flush the front edge of the top with the sides. See Figure 24.

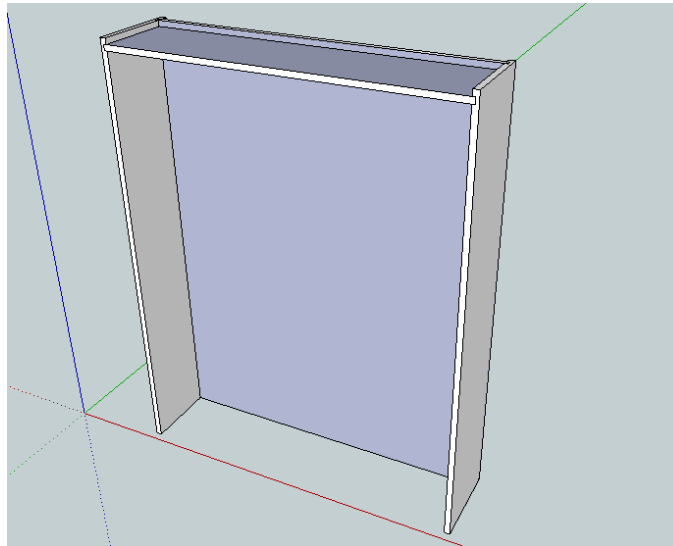

Figure 24: Top Cabinet with Sides, Back and Top

9. The top cabinet's face frame can then be installed. If pocket screws are used for this step, they are going to be more conspicuous, so consider using a biscuit joiner or simply brad nails. Remember to glue and clamp the assembly together. See Figure 25.

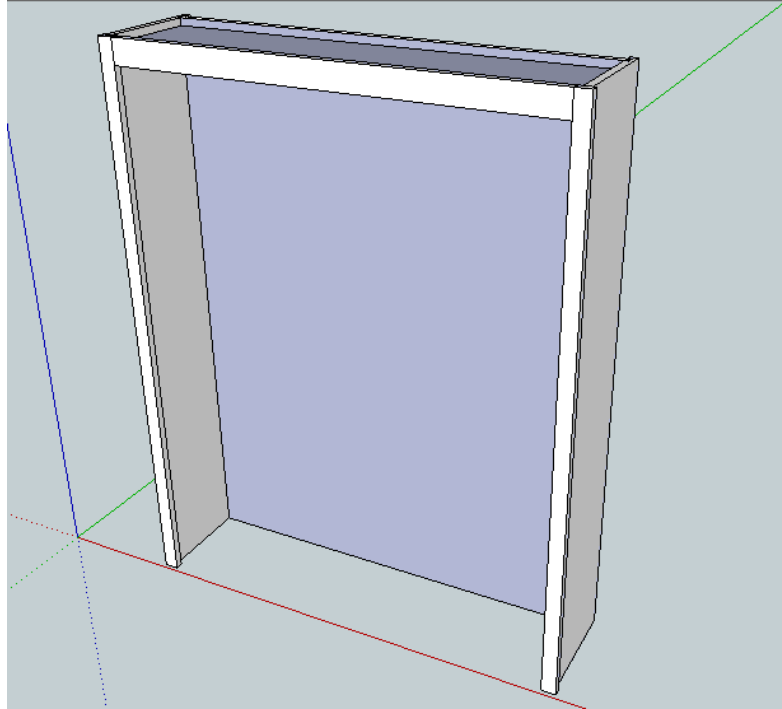

Figure 25: Top Cabinet Assembled

10. The shelves can now be made. Glue and nail the shelf fronts to their matching plywood boards. I prefer to have the shelf front sit about $\frac{1}{4}$ " higher than the top of the shelf so as to provide a catch for objects on the shelf.
11. Now would be a good time to add the shelf pin holes using the Rockler jig or your own homemade jig. You can watch a [quick video here](#) on how to use the Rocker jig.

Finishing

Before painting or staining, every surface that will receive a finish should be sanded. I used a 120 grit sandpaper on my random orbital sander and followed up with 220 grit.

This cabinet can be finished with a variety of primers and paints depending upon your requirements. For this particular cabinet, I sprayed on two coats of primer and brushed on two coats of regular latex paint to match the trim work in my home. Higher quality cabinet paint is preferred since it provides better adhesion, leveling and finish quality. Lacquer is also a solid option. If using normal latex paint, allow the cabinet to dry for several days to a couple of weeks for maximum adhesion. Otherwise, objects you place on the cabinet may remove paint when they are moved.

Installation

The bottom cabinet should be installed first. If you plan on adding baseboard molding to the cabinet, either remove the molding from the wall first or notch the cabinet to slip over the wall molding. If the wall is uneven, the cabinet may be scribed up to $\frac{3}{4}$ " in depth to allow for a flush mount. The bottom cabinet should be secured to the wall studs using the proper length screws and finish washers inside the cabinet. Use proper judgment to determine if the cabinet is adequately secured to the wall. Give it a solid couple of yanks away from the wall to make sure it doesn't pull away easily. The cabinet must be installed into wall studs.

The top cabinet merely rests on the bottom cabinet and is then secured to the wall studs using the same hardware as the bottom cabinet. Ensure the top cabinet is centered onto the bottom cabinet before securing to the wall. You may want to align your screw hole height locations with the same height as the shelves. The hardware will then not be noticeable since they'll be behind the shelves. Use proper judgment to determine if the cabinet is adequately secured to the wall. Give it a solid couple of yanks away from the wall to make sure it doesn't pull away easily. The cabinet must be installed into wall studs.

With the cabinets mounted, you can install the doors adjusting the hinge screw location to properly center the doors. Feel free to also add the door stops and any knob hardware you prefer.

The baseboard and crown molding can next be installed. I used 3-1/4" high baseboard molding and 2-1/8" crown molding. If your home has bigger molding and you would like the cabinet to match it, contact me for custom dimension resizing if available.

The cabinet should also be caulked to the wall for a more built-in look. Throw in your shelf pins and add your shelving and you should be done.

Resources

These plans were based on a series of blog posts that appeared on Our Home from Scratch. There are a number of posts on Our Home from Scratch that contain similar content to the work described in these plans. If something you've read here is unclear, you may want to refer to those posts for clarification. The [Large Built-In Cabinet Recap Post](#) contains links to nearly all of the work done on our blog for this project. If at any time, you get stuck on something or have a question, you can email me at John@ourhomefromscratch.com.

There are also a number of videos done by our blog for a different cabinet project, but the processes are similar. Those videos may be helpful if you've never done some of the techniques described in these plans.

1. [Face Frame Construction](#)
2. [How to Cut Plywood](#)
3. [How to Cut Grooves and Dados](#)
4. [How to Assemble a Cabinet](#)

That's it. If you find any errors or have any suggestions for improvement, drop us a line at John@ourhomefromscratch.com

Thanks!!

